

BATTEMAX

User's Manual

LiFePO4 Golf Cart Batteries

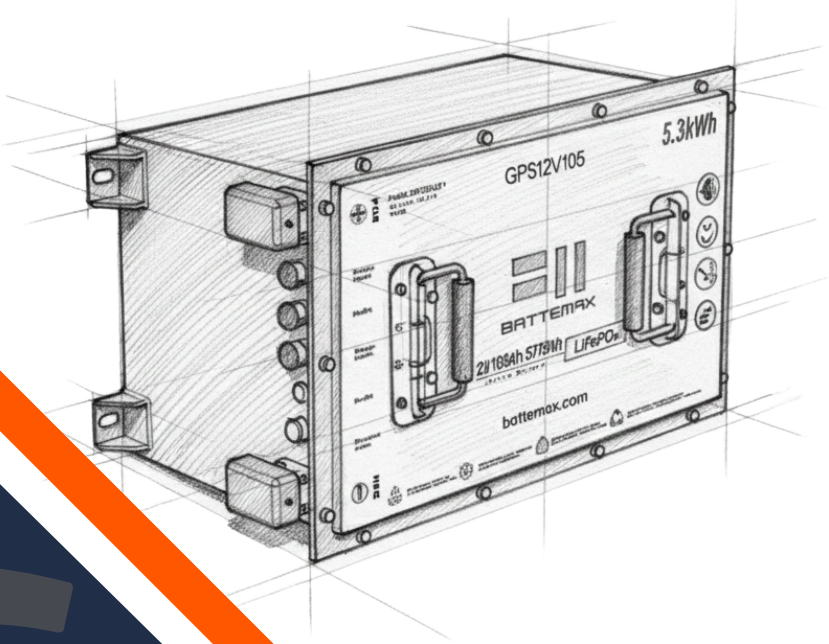

TABLE OF CONTENTS

Golf Cart Battery User Manual

1.	App User Instructions	1
2.	Troubleshooting Instructions	3
3.	Battery Components and Install instructions	7
4.	Read Before Use	13
5.	Safety Instructions While Using Batteries	13
6.	Safety Instructions While Charging Batteries	15
7.	Safety Instructions While Discharging Batteries	16
8.	Safety Instructions While Transporting and Storing Batteries	16
9.	Limited Warranty Policy	18
10.	Contact Us	19

Thank you for choosing the **BatteMax** Brand lithium battery series.

To ensure optimal performance and reliable after-sales support, please read the user manual carefully before use.

* Before first use, please make sure to **FULLY** charge the battery.

Register your battery

Please register your battery on **BatteMax** App to activate 10-year warranty within 30 days of purchase.

1. App User Instructions

Scan one of following QR-codes with your smartphone or search "BATTEMAX" in iOS App Store or Google Play Store to download **BatteMax** App.



iOS App Store



Google Play Store

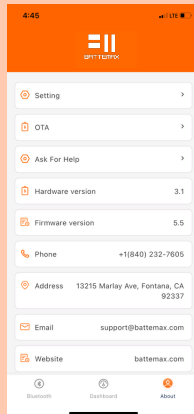
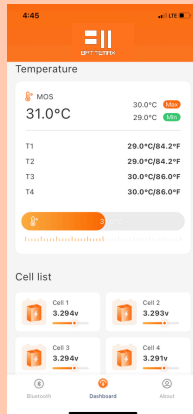
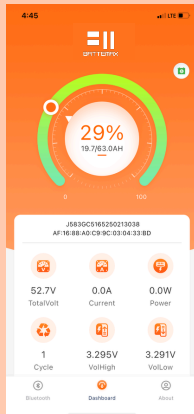
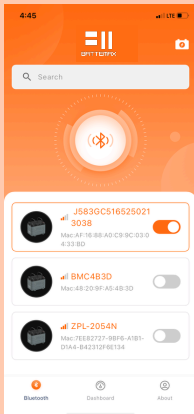

1.1 Bluetooth

➤ **Function Description:**

Used to connect the battery's Bluetooth module, displays a list of nearby battery devices available for connection, sorted by signal strength.

➤ **Operation Instructions:**

You can name the device (it is recommended to use YOUR BUSINESS abbreviation and last 6 digital of the Series Number on the battery, such as "515000") to prevent incorrect connections.

To connect, Bluetooth and location services must be enabled, and devices can be scanned or searched by matching codes to complete the connection.

Auto-Connect: Once connected successfully, the device will auto-connect each time Bluetooth is turned on; if manually disconnected or turned off, it must be reconnected.

Note: Some Android phones may require manual activation of scan permissions.

1.2 Dashboard

➤ **Function Description:**

Displays the overall status information of the battery.

➤ **Display Content:**

Real-time display of key parameters such as battery voltage, current, and temperature.

Alarm and Protection Status: These status details are hidden under normal conditions. When the battery triggers an alarm or protection, the specific protection information will be displayed; when the protection is cleared, these details will be hidden again.

Cell Balancing: When cell balancing occurs, the related status will be shown; once the balancing is complete, the information will be hidden again.

1.3 Cells

- **Function Description:**
Provides detailed information on the specific status of each battery cell.
- **Display Content:**
Real-time voltage, temperature, and balancing status of each cell, aiding in monitoring battery health.

1.4 About

- **Function Description:**
Provides features such as historical data statistics, system language switching, and online help.
- **Display Content:**
Real-time display of key parameters such as battery voltage, current, and temperature.

Alarm and Protection Status: These status details are hidden under normal conditions. When the battery triggers an alarm or protection, the specific protection information will be displayed; when the protection is cleared, these details will be hidden again.

Cell Balancing: When cell balancing occurs, the related status will be shown; once the balancing is complete, the information will be hidden again.

2. Troubleshooting Instructions

- In the **Dashboard - Protection** section, the system provides real-time feedback on the battery's protection status:
 - **Normal Status:** When the battery is functioning normally, the interface displays a green "Normal" indicator. This confirms that no abnormal conditions are present.
 - **Abnormal Status:** When a protection event or fault is detected, the "Normal" indicator will be replaced by a specific Error Code. This code identifies the nature of the fault or protection trigger, allowing for quick diagnosis.

➤ Find BMS Error Codes in Application:

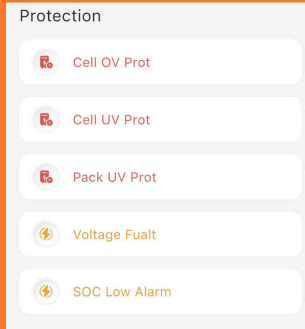
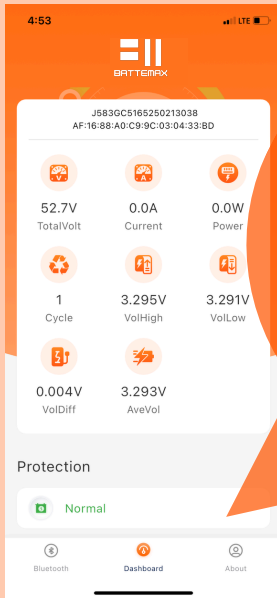

➤ Online BMS Error Codes Lookup:

battermax.com/tech-support/

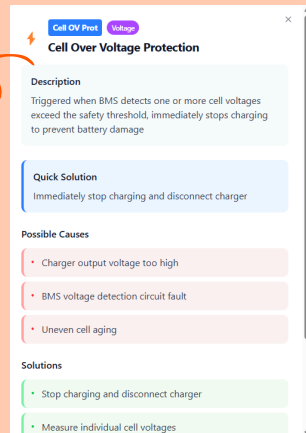
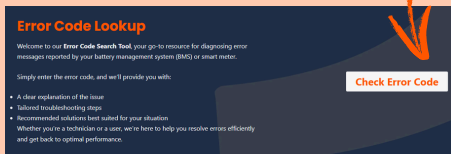

Error Codes	Description
Cell OV Prot	Cell Over Voltage Protection
Pack OV Prot	Pack Over Voltage Protection
Full CHG Prot	Full Charge Protection
Cell UV Prot	Cell Under Voltage Protection
Pack UV Prot	Pack Under Voltage Protection
CHG OT Prot	Charge Over Temperature Protection
CHG UT Prot	Charge Under Temperature Protection
DSG OT Prot	Discharge Over Temperature Protection
DSG UT Prot	Discharge Under Temperature Protection
MOS OT Prot	MOS Over Temperature Protection
SC Prot	Short Circuit Protection
DOC Prot	Discharge Over Current Protection
COC Prot	Charge Over Current Protection
Amb. OT Prot	Ambient Over Temperature Protection
Amb. UT Prot	Ambient Under Temperature Protection

Error Codes	Description
Temp. Fault	Temperature Acquisition Fault
Voltage Fault	Voltage Acquisition Fault
DSGFET Fault	Discharge MOSFET Fault
CHGFET Fault	Charge MOSFET Fault
Cell Unbalance	Cell Unbalance Alarm
Amb. OT Alarm	Ambient Over Temperature Alarm
Amb. UT Alarm	Ambient Under Temperature Alarm
SOC Low Alarm	State of Charge Low Alarm
MOS OT Alarm	MOS Over Temperature Alarm
Cell UV Alarm	Cell Under Voltage Alarm
Pack UV Alarm	Pack Under Voltage Alarm
Cell OV Alarm	Cell Over Voltage Alarm
Pack OV Alarm	Pack Over Voltage Alarm
DOC Alarm	Discharge Over Current Alarm
COC Alarm	Charge Over Current Alarm

3.1 Battery

➤ Models Covered and Battery Specifications

	51.2V 105Ah	38.4V 105Ah	51.2V 65Ah	70.4V 105Ah	51.2V 150Ah
Nominal Voltage	51.2V	38.4V	51.2V	70.4V	51.2V
Working Voltage	41.6V- 58.4V	30V - 43.8V	41.6V- 58.4V	57.5V- 83.95V	41.6V- 58.4V
Nominal Capacity	105Ah	105Ah	65Ah	105Ah	150Ah
Energy	5376Wh	4032Wh	3328Wh	7728Wh	7680Wh
Recom. Charging Current	50A	50A	35A	50A	50A
Max Charging Current	100A	75A	35A	105A	100A
Max Con. Discharge	250A	200A	200A	300A	250A
Charging Temp. Range	32°F to 113°F	32°F to 113°F	32°F to 113°F	32°F to 122°F	32°F to 113°F
Discharging Temp. Range	-4°F to 122°F	-4°F to 131°F	-4°F to 122°F	-4°F to 149°F	-4°F to 122°F
IP Rating	IP65	IP65	IP65	IPX4	IP65
Certifications	MSDS UL38.3 IEC13849	MSDS UL38.3 IEC13849	MSDS UL38.3 IEC13849	MSDS UL38.3 IEC13849	MSDS UL38.3 IEC13849

3.2 Gauge Instructions

➤ Operating Conditions:

Working Temperature: -4°F ~ 158°F

Protection Level: IP65

Working Humidity: 20% ~ 90% RH

➤ Wiring Instructions:

Red: +12V ~ 60V

Green: 485-A / CAN HIGH

Blue: 485-B / CAN LOW

Black: GND

Yellow: 12V / 40mA

By switching connections, the LCD display content can be controlled

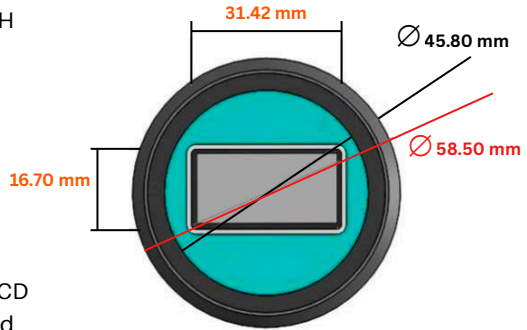

➤ Display Content:

Battery SOC (State of Charge), Total Voltage, Current Runtime, Alarm Codes

➤ Display Interface (Illustration or Simulation Example Explanation):

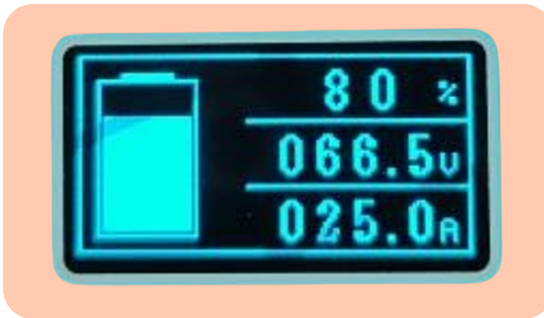

➤ Alarm Conditions (Text with Accompanying Diagram Explanation):

Alarm Method: When SOC \leq 10%, the buzzer sounds for 3 seconds, pauses for 5 seconds, and the indicator "!" flashes along with the alarm. This cycle lasts for one minute before stopping.

For other alarm conditions, the buzzer does not sound. The corresponding indicator flashes for 3 seconds, pauses for 5 seconds, and continues to cycle until the fault is resolved.



Alarm Code

Alarm Code	Alarm Condition
!01	SOC \leq 10%
!02	Discharge Short Circuit
!03	Cell Open Circuit
!04	Temperature Open Circuit
!05	Cell Overvoltage
!06	Cell Under-voltage
!07	Overall Overvoltage
!08	Total Voltage Too Low
!09	Charging Over-temperature
!10	Discharge Over-temperature
!11	Charging Low Temperature
!12	Discharge Low Temperature
!13	Charging Temperature Difference
!14	Discharge Temperature Difference

3.3.1 Charger Instructions

- All BM Brand golf cart lithium batteries are compatible with both 15A and 25A chargers. The 105Ah batteries are supplied with a standard 15A charger, while the 150Ah batteries are supplied with a 25A charger.

If you require a 25A charger for use with a 105Ah battery, it can be purchased separately from our official website.

www.battemax.com

	15A	25A
Rated Input Voltage Range	AC 100~240V	AC 100~240V
Input Current	≤8.5A	≤12A
Rated Output Voltage	48V	48V
Maximum Output Voltage	58.4V	58.4V
Maximum Output Current	15A	25A
Power Factor	≥0.99	≥0.99
Efficiency	≥90%	≥91%
Maximum Output Power	840W	1200W

3.3.2 Indicator Light Status Definition

- The indicator light provides clear visual signals of the battery's operating status, charging progress, and possible faults. By observing the color and flashing patterns of the light, users can quickly understand the condition of the battery without additional tools.

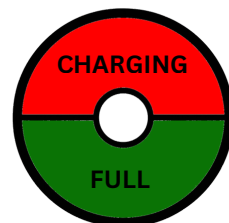

Status	Description	
Standby Indicator	The red and green lights flash alternately.	
Battery Indicator	Charging	Red light flashes
	Fully charged	Green light stays on
Fault Indicators	Output Over current	Red Green Red - - -
	Startup Fault	Red Green - - - -
	Bias Fault	Red Green Red Green Red Green -
	Reference Voltage Fault	Green Red Green Red Green Red -
	Input AC Voltage Fault	Red Green Red Green Red -
	External Temperature	Red Green Red Green - -
	Internal Temperature	Green Red - -
	Relay Fault	Green Red Green - -
	Self-Test	Green Red Green Red - -
	Communication Fault	Red Green Red Green Red Green Red -
Charge Shutdown Indicator	Green light stays on	

4. Read Before Use

➤ Precautions Before Use:

- **Personal Protection:** Wear protective goggles and rubber gloves when handling the battery.
- **Tool Usage:** Use insulated tools with rubber or plastic handles.
- **Keep Away from Flames:** Keep ignition sources and flammable materials away from the battery.
- **Remove Metal Objects:** Remove all metal jewelry or other items when handling the battery.
- **Avoid Short Circuits:** Do not place objects on the battery.
- **Ensure Secure Connections:** Check that all electrical connections are secure and undamaged.
- **Proper Handling:** Use only built-in handles for carrying/installing the battery.

5. Safety Instructions While Using Batteries

Precautions When Using the Battery

5.1 Safety Guidelines

- **Please follow the safety guidelines below when using the battery.** Battery performance and capacity may be affected by factors such as temperature, load, state of charge, and aging. Improper use of the battery may result in overheating, swelling, or fire, which could cause serious injury.
 - Please do **NOT** throw the battery into fire or expose it to heat sources.
 - Please do **NOT** install the battery in reverse, as this may result in reversed polarity and permanent damage.
 - Please do **NOT** use metal objects (e.g., wires) or conductive materials (e.g., carbon rods) to connect the positive and negative terminals.
 - Please do **NOT** carry or store the battery together with metal items such as necklaces, hairpins, or other conductive objects.
 - Please do **NOT** puncture the battery with sharp objects, strike it with tools, step on it, or subject it to strong impact or vibration.
 - Please do **NOT** immerse the battery in water or other liquids, and do **NOT** store it in excessively humid environments for prolonged periods.

5.2 Disassembly

- Please do **NOT** attempt to disassemble or modify the battery. The battery is equipped with protective devices, and damage to these components may result in overheating, swelling, or fire during operation.

5.3 Heat and Flames

- Please do **NOT** place the battery near open flames, stoves, or other high-temperature objects. Please do **NOT** expose the battery to direct sunlight.

5.4 Children

- Please do **NOT** allow children to use the battery unsupervised. Children must use the battery only under adult supervision to ensure safe operation in accordance with the user manual.

5.5 Disposal

- Please do **NOT** dispose of the battery improperly. Always take it to a specialized recycling facility in compliance with local regulations.

5.6 Abnormalities

- Please do **NOT** ignore abnormal signs. If the battery emits odor, becomes excessively hot, swells, discolors, or deforms during use, charging, or storage, discontinue use immediately and contact the manufacturer or an authorized service provider.

5.7 Prohibited Environments

- Please do **NOT** place the battery in a microwave, high-pressure container, or induction cooker.

5.8 Leakage

- Please do **NOT** ignore leakage accidents. If the battery leaks and fluid enters your eyes, do **NOT** rub them. Rinse immediately with clean water and seek medical attention to avoid serious injury.

6. Safety Instructions While Charging Batteries

It is strongly recommended to use the original charger provided with the battery for optimal safety and performance.

6.1 Charging Current

- Please do **NOT** exceed the maximum charging current specified in this user manual. Using a higher current than recommended may degrade charging and discharging performance, compromise mechanical integrity, reduce safety, and may result in overheating or leakage.

6.2 Charging Voltage

- Please do **NOT** exceed the cutoff charging voltage specified in this user manual. The charger must be designed to comply with this requirement. If the battery pack voltage surpasses the cutoff threshold, performance, safety, and reliability may be compromised, potentially causing overheating, swelling, or leakage.

6.3 Charging Temperature

- Please do **NOT** charge the battery outside the ambient temperature range of **32°F to 113°F (0°C to 45°C)**. In cold weather, if charging cannot proceed normally, it may resume once the temperature rises above **41°F (5°C)**. This safeguard ensures both safety and long service life of the lithium battery.

6.4 Reverse Charging

- Please do **NOT** connect the battery terminals in reverse. Reverse charging is strictly prohibited, as it prevents proper charging, damages electrochemical stability, reduces safety, and may lead to overheating or leakage.

6.5 Indoor Charging

- Please do **NOT** charge the battery indoors. Always perform charging in a well-ventilated outdoor environment to prevent safety hazards.

7. Safety Instructions While Discharging Batteries

7.1 Discharge Current

- Please do **NOT** exceed the maximum discharge current specified in this user manual. High discharge currents may significantly reduce cell capacity, impair performance, and cause overheating.

7.2 Discharge Temperature

- Please do **NOT** discharge the battery outside the recommended ambient temperature range of **-4°F to 131°F (-20°C to 55°C)**. Operating beyond this range may damage the battery and compromise safety.

7.3 Over-discharge

- Please do **NOT** allow the battery to enter an over-discharge state. During prolonged periods of non-use, the cell may self-discharge. To prevent over-discharge, recharge the battery periodically and maintain it at approximately 50% state of charge. Failure to do so may result in permanent loss of performance and battery functionality.

8. Safety Instructions While Transporting and Storing Batteries

8.1 Transportation

- During transportation, the battery pack must be protected from severe vibration, impact, or compression, and must be kept away from direct sunlight and rain. Handle with care, and avoid dropping, rolling, or applying heavy pressure.

8.2 Storage

- The battery pack must be stored indoors in a clean, dry, and well-ventilated environment with an ambient temperature of **32°F to 113°F (0°C to 45°C)** and relative humidity of $\leq 75\%$.

Avoid contact with corrosive substances and keep away from heat sources and open flames. The battery pack must not be dropped, must never be stacked higher than four layers, and must always be stored upright with the front side facing up.

8.3 Forbidden Matters

- The following practices are strictly prohibited, as they may compromise the safety, performance, and reliability of the battery:
- **Disassembly, Heating, or Burning:** Disassembling, heating, or burning the battery may cause fire, explosion, or burns.
 - **Improper Components:** Using components with mismatched voltage or current ratings can lead to malfunction or safety risks.
 - **Short Circuits:** Touching or connecting terminals without manually turning off the battery may result in a short circuit.
 - **Physical Damage:** Striking, dropping, puncturing, or stepping on the battery may cause irreversible damage or hazards.
 - **Poor Contact:** Connecting or disconnecting terminal wiring before removing the load can result in poor contact or arcing.
 - **Loose Connections:** Failure to maintain the correct connection torque may cause overheating or malfunction.
 - **Sparks and Flames:** Always keep sparks and open flames away from the battery.
 - **Incorrect Charger Settings:** Using charger settings outside the recommended specifications may damage the battery.
 - **Unsafe Usage:** Charge and discharge only in a safe, suitable environment and avoid extreme conditions.
 - **Lack of Maintenance:** Regularly inspect and maintain the battery to ensure it remains in optimal condition.
 - **Ignoring Instructions:** Always follow this user manual for correct use and maintenance to guarantee safety and reliability.

WARNING

Failure to follow the above instructions may result in fire, explosion, severe injury, or permanent damage to the battery. BatteMax shall not be held liable for any harm or damage caused by misuse, modification, or failure to follow this manual. Users are fully responsible for safe operation and maintenance.

9. Limited Warranty Policy

9.1 Warranty Coverage

➤ The battery purchased from **BatteMax** is covered by a limited warranty of up to 10 years, subject to the following terms and conditions:

- **Battery**
 - **Within 5 years** (0–60 months): Free repair or replacement for defects in materials or workmanship.
 - **6th - 8th year** (61–96 months): Customer may replace the battery by paying 50% of the Manufacturer's Suggested Retail Price (MSRP).
 - **9th -10th year** (97- 120 months): Customer may replace the battery by paying 70% of the Manufacturer's Suggested Retail Price (MSRP).
 - **Beyond 10th year** (after 120 months): Warranty coverage ends.
- **Parts**
 - **Within 2 years** (0-24 months): Free repair or replacement for defects in materials or workmanship.

This limited warranty is **non-transferable** and applies only to the original purchaser.

9.2 Warranty Exclusions and Void Conditions

- This limited warranty does not apply, and shall be considered void, under any of the following conditions:
- The product has been stored, installed, used, or charged in a manner contrary to the manufacturer's instructions, data sheet, or recognized industry best practices.
 - The product has been opened, modified, or tampered with in any way, including altering or removing date codes.
 - The product has been used for applications or in manners for which it was not designed.
 - The product has been stolen, lost, or removed from customer control (except in the normal course of business).
 - The product has been subjected to extreme environmental conditions, including excessive heat, cold, humidity, or other limitations defined in the manufacturer's instructions or data sheet, during storage or use.

- Damage has resulted from improper installation, use, maintenance, or service.
- Damage has resulted from impact, accident, collision, or drop.
- The battery has not been charged for a period exceeding **one (1)** year.
- The battery has been stored under inappropriate conditions, including exposure to temperatures above **140°F (60°C)** or below **-40°F (-40°C)**.
- Any indirect, incidental, or consequential losses or damages caused by product failure.
- Transportation costs associated with warranty claims, including fees incurred by the manufacturer or customer for product shipment, are not included and must be borne by the customer/dealer.

9.3 Warranty Claims

- All warranty claims must first be submitted to the original point of purchase. If the dealer or intermediary is unable or unwilling to process the claim, the end user should contact **BatteMax** directly.
- During the warranty period, **BatteMax** or its authorized representatives will, at their discretion, repair or replace the product in accordance with the terms of this Limited Warranty Policy.

10. Contact Us

Thank you for choosing **BatteMax** batteries. To ensure safe and reliable performance, please follow the instructions in this User Manual carefully.

If you encounter any issues or require assistance, please do not hesitate to contact us. Our service team is committed to providing you with timely, professional, and satisfactory support.

Service Hotline (Pacific Time): +1 (840) 232 - 7605

Email: support@battemax.com

Website: www.battemax.com





BATTEMAX